

Introduction

The progress of the advanced computing cores coming from microprocessor manufacturers such as Intel® and AMD® have necessitated a change in the topology of the switching regulators traditionally used to power these processor cores. Multiphase buck regulators have proven to be the topology of choice for such high-current applications. However, the distributed power system architecture of these computers continue to have a need for other sub-system specific voltages. The ISL6432 was created to complement a multiphase buck controller in creating a complete power solution for the typical Pentium 4 system. Athlon™-class processor based systems (AMD) may also benefit from the ISL6432. [1]

The ISL6432EVAL1 evaluation board embodies a 4-output regulator solution targeted at supplying power to the system memory (2.5V), system clock (2.5V), ICH/MCH chip set core (1.8V), and the 4X AGP video (1.5V), with provisions for ACPI power management implementation. [2]

Quick Start Evaluation

Important!

To facilitate the evaluation of the ISL6432 in a typical setting, the ISL6432EVAL1 was designed to be powered primarily from an ATX supply. However, the board does have hook-up turret terminals that allow it to be piggy-backed in an actual computer system, or be powered from standard laboratory power supplies

If an ATX power supply is used to power the board (using the on-board 20-pin connector), remember that regulation of most ATX supplies is generally dependent on the presence of a DC load on the main 5V output. Therefore, for best results, have a 5Ω/25W-50W power resistor connected to the 5V output of the ATX supply (take necessary precautions, as the resistor may get very hot). [3]

Circuit Setup

Before connecting an input supply to the board, consult the circuit schematic and familiarize yourself with the various connection options offered by the ISL6432EVAL1.

► Set Switches

Ensure the 'ATX ON' (SW1) switch is in the off position (away from 'ATX ON' marking) and 'S3/S5' (SW2) switch is in the middle position (away from 'S3' or 'S5' marking).

SW3 helps with the control of the various outputs in ACPI shutdown states. To avoid having the powerful output drives (of the regulators that have to be off in certain sleep states) hold the outputs within regulation, they have to be actively kept off by pulling the corresponding FB pins above 1.25V.

Each output can thus be turned off or kept running in S3 and/or S5 states, with corresponding consequences. For initial evaluation, we recommend closing positions 2, 4, and 6-8 (see Figure 1 for detail). Unless otherwise specified, this recommended SW3 configuration was employed throughout testing of the board described in this application note.

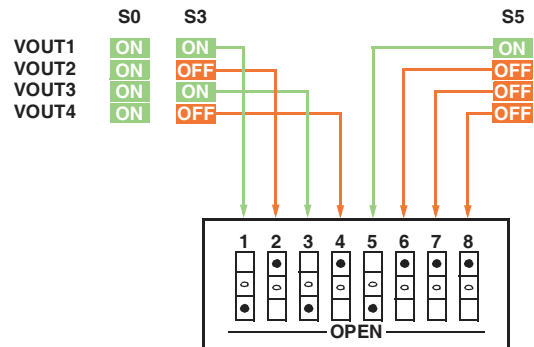

FIGURE 1. SW3 DETAIL (RECOMMENDED INITIAL CONFIGURATION) - SLEEP STATES SUPPORT

► Set Jumpers JP1-4

JP1 and JP3 select the on-board input voltage for the linear pass elements corresponding to the VOUT3 and VOUT4 outputs, respectively. One recommended configuration for initial evaluation is with JP1 populated in the '2.5VIN' position and JP3 in the '3.3VIN' position.

JP2 and JP4 select the '+3.3VDUAL' as the input for the two linear pass elements mentioned above. If an external 3.3VDUAL source is supplied, either pass element (Q4 and/or Q5) may be powered from this source by moving the respective header jumper from JP1 or JP3, onto JP2 or JP4, respectively.

► Hookup Guide Using Standard Bench Supplies

Connect a 5V, 16A supply to the +5VDUAL input and a 3.3V, 4A, supply to the +3.3VIN input. Another 3.3V, 4A supply may be needed for the optional +3.3VDUAL input if either JP2 or JP4 are populated. Connect typical loads to all the evaluation board's outputs. Consult Table 1 for maximum loads supported by the design of the in the configuration received; consult the *Modifications* section for information on modifying the evaluation board to meet your special needs.

► Hookup Guide Using a Standard ATX Supply

Connect the 20-pin ATX connector to the on-board J1 mating connector. Connect typical loads to all the evaluation board's outputs. Consult Table 1 for maximum loads supported by the design of the in the configuration received; consult the *Modifications* section for information on modifying the evaluation board to meet your special needs.

► Hookup Guide for Piggy-Backing the Evaluation Board Into Your System

Connect GND, +5VDUAL, +3.3VIN, and +3.3VDUAL turret terminals to the corresponding voltages present on your system board. For ACPI functionality, connect $\overline{S3}$ IN (TP9) and $\overline{S5}$ IN (TP10) to your system's $\overline{S3}$ and $\overline{S5}$ signal source. Connect the evaluation board's outputs to the corresponding power planes in your system. Consult Table 1 for maximum loads supported by the design of the in the configuration received; consult the *Modifications* section for information on modifying the evaluation board to meet your special needs.

Operation

► Provide Power to the Board

Turn on the bench supplies or the system onto which the board is piggy-backed.

If using an ATX supply, plug it into the mains. If the supply has an AC switch, turn it on. The '5VSB', '5VDUAL', and 'S0' LEDs should light up, indicating the presence of 5V standby and 5V dual voltages on board, as well as indicating active state selection. Flip on the 'ATX ON' switch and shortly thereafter '5VIN' and 'ATX PGOOD' LEDs should light up indicating the presence of main ATX 5V on board, as well as the ATX PGOOD indication.

► Examine Start-Up Waveforms / Output Quality Under Varying Loads

Start-up is immediate following application of bias voltage. Using an oscilloscope or other laboratory equipment, you may study the ramp-up and/or regulation of the controlled voltages.

In either state (active or S3, S5) vary the output loads to simulate computer loads typical of the specific operating state the circuit is in. Observe the limitations of the circuit while in S3 or S5 states: all output power, along with any necessary operating bias current, is delivered from the ATX supply's 5VSB output.

► Examine State Transitions

For subsequent transitions into/out of standby states, leave the main ATX outputs enabled (SW1 on); the on-board circuitry will automatically turn them off when entering a standby state and re-enable them when transitioning back into active state. To enter a standby state, flip SW2 to the position indicating the desired standby state. The 'S3' LED lights up to indicate S3 standby state, while S5 state is indicated by illumination of the 'S5' LED. Active state indication is performed by the 'S0' LED.

Fault Handling

In case of a fault condition (output undervoltage on the linear outputs, or overcurrent on the switching output), the faulting output shuts down and undergoes an individual re-start attempt every three soft-start (SS) intervals. Review the appropriate data sheet section for more detail.

Reference Design

General

The evaluation board is built on 1-ounce, 4-layer, printed circuit board (see last three pages of this application note for layout plots). Most of the components specific to the evaluation board alone, which are not needed in a real computer application, are placed on the bottom side of the board. Left on top of the evaluation board are the components necessary to exemplify a typical application, as well as the user interface (input/output terminals, test points, switches, etc.).

Design Envelope

Although a real-life computer system application might have different requirements, the ISL6432EVAL1 board was designed to meet the maximum output loading described in Table 1. Note the fact that the sleep state output currents are likely limited only by the ATX power supply's 5VSB output capability. As all the outputs operate the same current paths in both active and standby states, standby state power dissipation capability equals that of active state. Dynamic output tolerances and current ratings can be adjusted by properly selecting the components external to the ISL6432.

TABLE 1. ISL6432EVAL1 MAXIMUM OUTPUT LOADING

| OUTPUT VOLTAGE | ACTIVE STATE | | SLEEP STATES | | TOL. (STATIC/DYNAMIC) |
|----------------|-----------------------|-----------------------|------------------|-----------------------|-----------------------|
| | I _{OUT} | dI _{OUT} /dt | I _{OUT} | dI _{OUT} /dt | |
| 2.5VMEM | 8.0A(pk) 3.0A(avg) | 1A/μs | 0.2A (Note) | 0.1A/μs (Note) | 3% / 5% |
| 2.5VCLK | 1.0A(pk) 0.4A(avg) | 0.1A/μs | OFF | OFF | 5% / 5% |
| 1.8VMCH | 3.0A(pk) 1.0A(avg) | 1A/μs | 0.1A | 0.1A/μs | 5% / 5% |
| 1.5VAGP | 3.0A(pk) 0.8A(avg) | 1A/μs | OFF | OFF | 5% / 5% |

NOTE: In real applications, this output is OFF in S4/S5; requires 1.8VMCH to derive power from the 3.3VDUAL supply (not provided on the ISL6432EVAL1).

From a thermal performance perspective, do not operate the evaluation board for extended periods of time at output current levels exceeding the design envelope, as detailed in Table 1.

Performance

Figures 2 through 8 depict the evaluation board's performance during typical operational situations. To simulate minimum loading conditions, unless otherwise specified, the outputs were loaded with 65Ω resistive loads.

Soft-Start Start-Up

Figure 2 shows a typical ISL6432EVAL1 start-up. For this capture, the ATX supply powering the board is turned on, at time t₀, with SW1 on and SW2 is in the S0 (middle) position. At time t₁ the input supply exceeds the power-on-reset (POR) threshold and the 2.5VMEM and 1.8VMCH outputs start ramping up toward their target value, which they reach

at time t2. Between t1 and t2, due to the fact the ATX 3.3V output has not come up already, the 2.5VCLK and 1.5VAGP outputs experience an undervoltage event which keeps them off for a period of three soft-start cycles. At time t3, the main ATX outputs start to ramp up. Time t4 signals the beginning of the 2.5VCLK and 1.5VAGP soft starts, with the outputs reaching their set point at time t5.

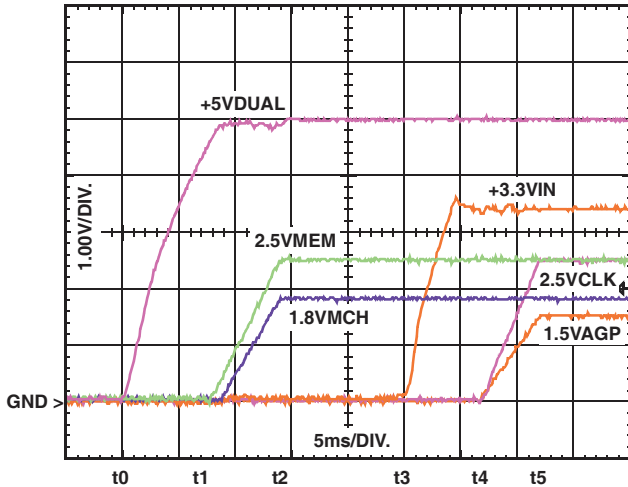

FIGURE 2. ISL6432EVAL1 START-UP

Active to Standby State Transition (S0 -> S3)

Figure 3 shows a typical active (S0) to S3 standby state transition. Prior to time t0, the ISL6432EVAL1 was operating in active state. At time t0, SW2 is switched into the ‘S3’ position. As a result, the main ATX outputs, as well as the 2.5VCLK and 1.5VAGP outputs are shut down. Even though the ATX is effectively shut down at time t0, the ATX PGOOD output signals the fact that the main outputs will go out of regulation only at time t1. At time t2, the ATX 3.3V outputs start to discharge, falling out of regulation. Throughout the transition, the 2.5VMEM and 1.8VMCH outputs rigorously maintain their regulation.

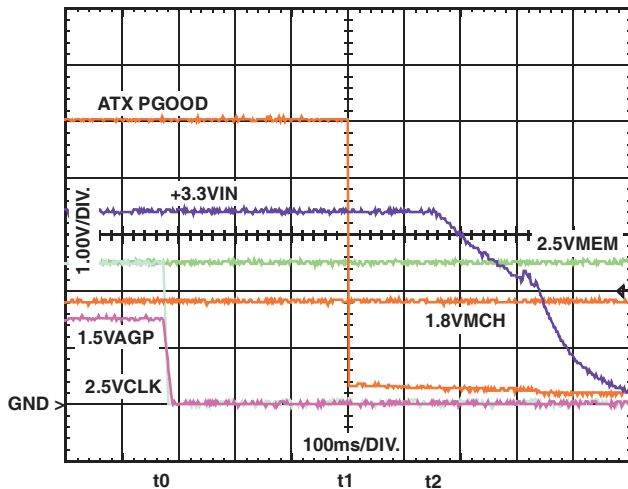

FIGURE 3. ACTIVE TO S3 STANDBY STATE TRANSITION

Standby to Active State Transition (S3 -> S0)

Figure 4 shows the reversal of the process described in Figure 3. By flipping SW2 back to the S0 (middle) position at time t0, the ATX supply’s main outputs are enabled, along with the ISL6432-controlled 2.5VCLK and 1.5VAGP outputs. Time t1 signals the return of the ATX PGOOD signal back to a high state. Noteworthy is the lack of perturbations in the 2.5VMEM and 1.8VMCH outputs during this state transition.

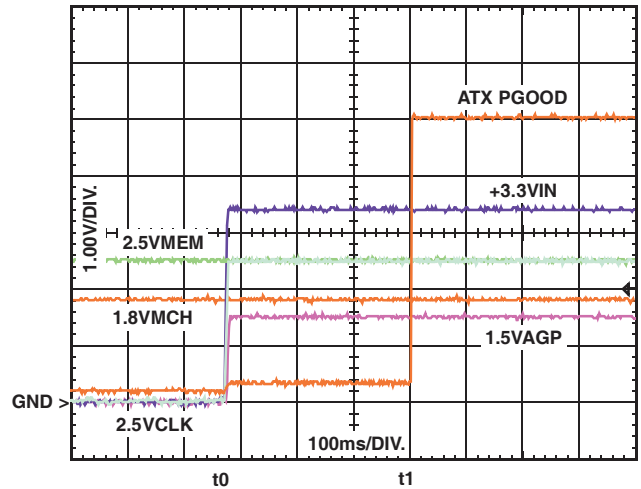

FIGURE 4. S3 STANDBY TO ACTIVE STATE TRANSITION

Due to the similar transition response, only S3 state transitions are detailed.

Transient Response

Figure 5 details the transient response of all four outputs controlled by the ISL6432 under the effect of concurrent loading. The characteristics of the loads the outputs were subject to during this test are listed in Table 2. To summarize the information: all outputs were transiently loaded with 10% to 100% of their maximum output rating, were under nominal current rate of change, a 40% duty cycle, and different frequencies resulting in random load overlapping. The test was designed to stress the application in a manner representative of a worst-case situation. Even under such loading, the ISL6432EVAL1 exhibits exemplary response and crosstalk immunity, both characteristics easily noticed in Figure 5.

TABLE 2. OUTPUT TRANSIENT LOADING DESCRIPTION

| OUTPUT | I _{OUT(MIN)} (A) | I _{OUT(MAX)} (A) | dI _{OUT} /dt (A/μs) | Frequency (Hz) |
|---------|---------------------------|---------------------------|------------------------------|----------------|
| 2.5VMEM | 0.8 | 8.0 | 1.0 | 1000 |
| 2.5VCLK | 0.1 | 1.0 | 0.1 | 800 |
| 1.8VMCH | 0.3 | 3.0 | 1.0 | 650 |
| 1.5VAGP | 0.3 | 3.0 | 1.0 | 1500 |

NOTE: All transients applied had a 40% duty cycle.

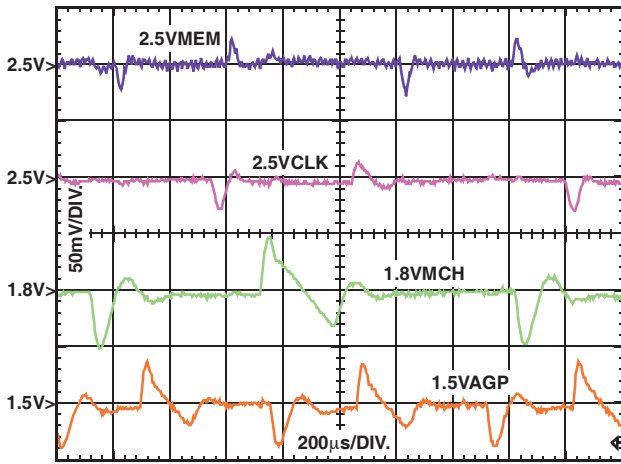

FIGURE 5. OUTPUT TRANSIENT RESPONSE (CONCURRENT LOADING OF ALL OUTPUTS)

Output Short-Circuit Protection

In response to an overcurrent event on the switcher’s output, or an undervoltage event on any of the linear outputs, the faulting regulator is shut down. Figure 6 exemplifies such a scenario on 1.5VAGP (VOUT4). At time t0, a short-circuit is applied to the 1.5VAGP output; as a result, the output and the ATX 3.3V input start to sag under the increasing output current. DRIVE4 responds by increasing the base drive for the pass element (Q5). At time t1, DRIVE4 reaches its output current limit. The ATX 3.3V output reflects the current limit event through the settling of the voltage seen between times t1 and t2. As the current drawn in current limiting from the ATX supply does not equal the output current drawn by the short-circuit, the 1.5VAGP output continues to drop. At time t2, the 70% undervoltage threshold is reached and the output is shut down.

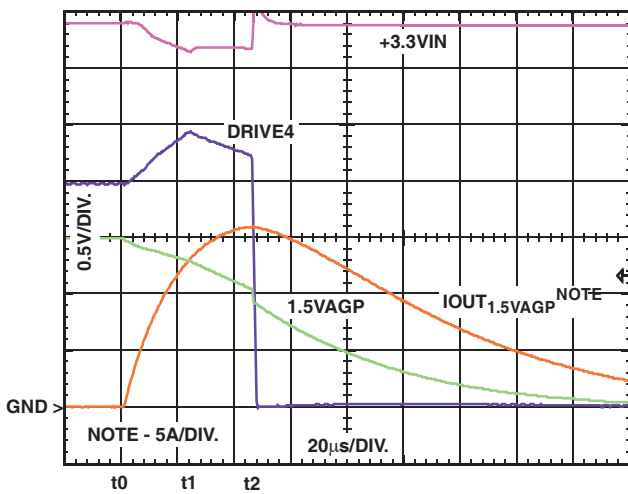

FIGURE 6. ISL6432EVAL1 VOUT4 UNDERVOLTAGE RESPONSE (SHORT-CIRCUIT PROTECTION)

Following an overcurrent shutdown, a restart attempt is performed after approximately three soft-start periods. Figure

7 zooms out of the picture presented in Figure 6 in order to detail the restart attempt under a continuous output short-circuit. Time t0 marks the application of the output short-circuit. At time t1, after approximately three soft-start intervals, DRIVE4 attempts to restart the output: the output voltage, and, consequently, the output current ramp up. As the output current ramps up, the DRIVE4 pin enters current limiting, and 25% into the SS ramp undervoltage monitoring is enabled. At time t2 the fault condition is detected and the output is shut down. The cycle repeats for as long as the short-circuit is present at the output.

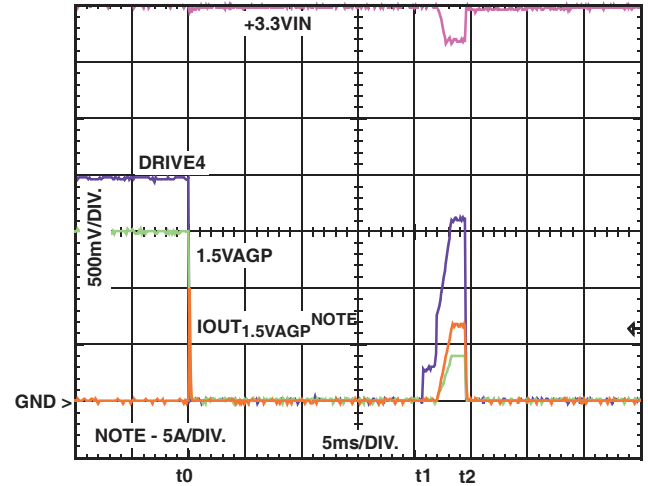

FIGURE 7. ISL6432EVAL1 VOUT4 HICCUP MODE UNDER APPLIED SHORT CIRCUIT

Switching Regulator Efficiency

Figure 8 highlights the evaluation board’s conversion efficiency with only the switching section loaded. The measurement was performed at room temperature with the linear outputs open and 100 LFM of air flow.

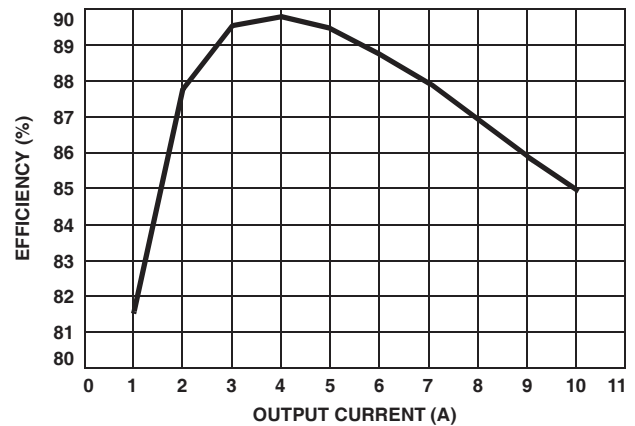

FIGURE 8. ISL6432EVAL1 SWITCHING REGULATOR MEASURED EFFICIENCY (ALL LINEAR OUTPUTS UNLOADED)

Modifications

Adjusting the Output Voltage

All outputs controlled by the ISL6432 are adjustable by means of the resistive divider connecting the FB pins to their respective outputs.

The switching regulator's output has provisions for droop implementation, unused in the shipping configuration. As R8's value plays in the feedback compensation, it is recommended VOUT1 is adjusted by adjusting R13 only.

If adjusting the output voltage of the linear regulators, please pay attention to the recommended resistor value selection guidelines described in the datasheet.

Improving Output Voltage Tolerance

The key to improving the output voltage tolerance is identifying the parameters which affect it, and then taking steps toward improving them.

High $dv/dtdv/dt$ spikes present in the output voltage waveform under highly dynamic load application (high dl/dt) are due to the ESR and the ESL of the output capacitance. These spikes coincide with the transient load's rising and falling edges, and decreasing their amplitude can be achieved by using lower ESR/ESL output capacitors (such as surface-mount tantalum capacitors), and/or the addition of more ceramic capacitors, which have inherently low ESR/ESL.

The addition of more input-side capacitance and decreasing the input-side capacitor banks' ESR can also help in situations where the input-side ripple is affecting the output regulation. Such an example is excessive ATX 3.3V ripple reducing the collector-to-emitter voltage available for Q3 (2.5V output setting), and thus inducing an output droop component. In such instance, the addition of input-side capacitance and reduction of the ESR component can reduce the output excursion.

Conclusion

The ISL6432EVAL1 evaluation board showcases a highly integrated approach to providing peripheral power control in Pentium 4 computer systems. Sophisticated internal circuits facilitate ACPI implementation with minimum effort and a reduced number of external components.

References

For Intersil documents available on the internet, see web site www.intersil.com/

- [1] *FN9019 Data Sheet*, (www.intersil.com/).
- [2] Advanced Configuration and Power Interface (ACPI) Specification, Revision 1.0, December 1996, Intel/Microsoft/Toshiba. (<http://www.teleport.com/~acpi/>).
- [3] ATX Specification, Version 2.02, October 1998, Intel Corporation (<http://www.teleport.com/~atx/>).

ISL6432EVAL1 Schematic (Continued)

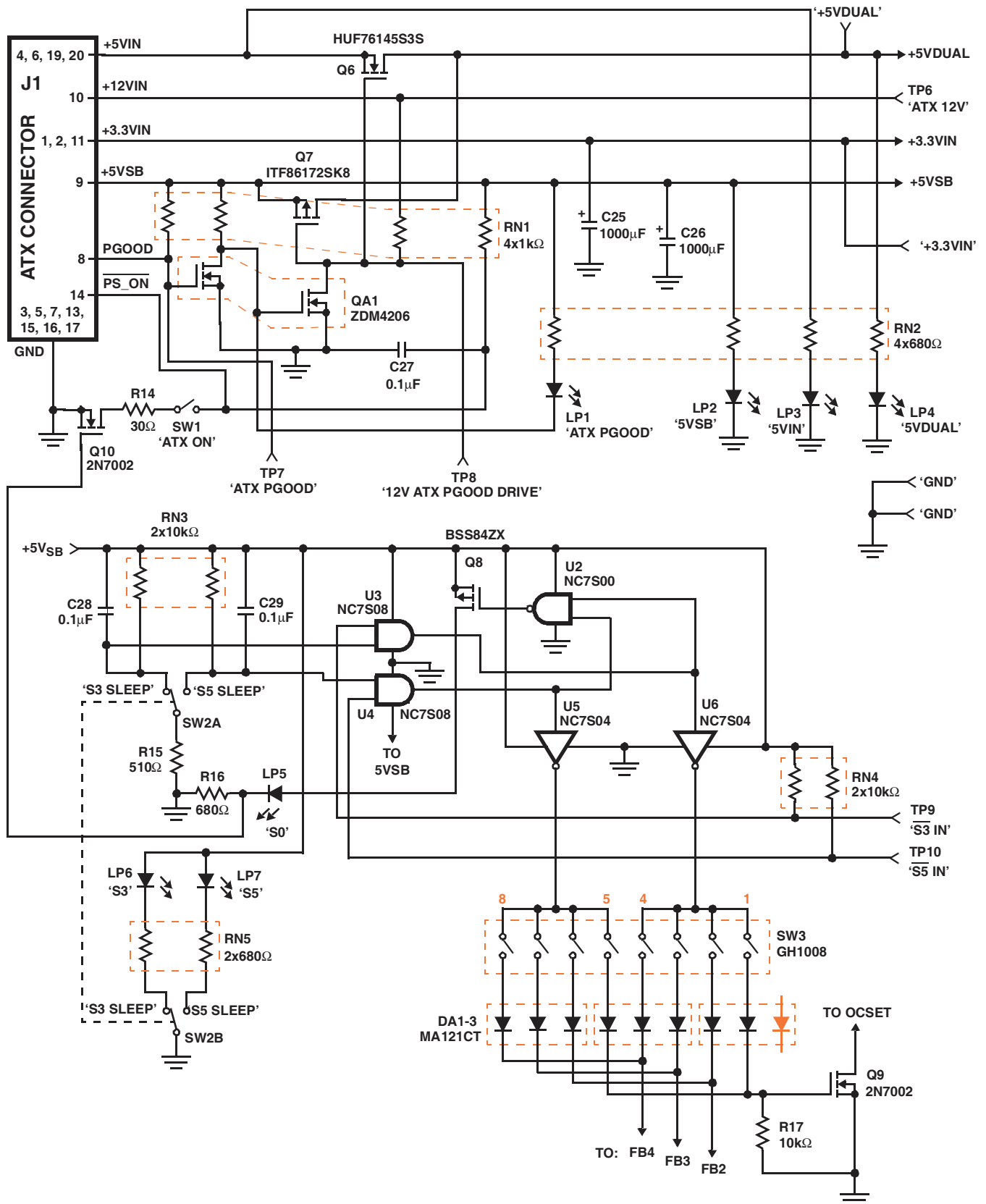

Bill of Materials for ISL6432EVAL1

| REFERENCE | PART NUMBER | DESCRIPTION | PACKAGE | MANUF. OR VENDOR | QTY |
|--------------------------|----------------------|---|----------------|------------------|-------|
| C1-3 | EEUFC0J122 | Al. Electrolytic Capacitor, 6.3V, 1200 μ F | 10 x 16 | Panasonic | 2 |
| C4 | TAJB106M006R | Tantalum Capacitor, 6.3V, 10 μ F | 3.0 x 4.0 | AVX | 1 |
| C5, 7, 9, 15, 16, 18, 23 | 1 μ F Ceramic | Ceramic Capacitor, Y5V, 16V, 1.0 μ F | 0805 | Any | 7 |
| C6 | 1000pF Ceramic | Ceramic Capacitor, X7R, 25V | 0603 | Any | 1 |
| C8 | 0.47 μ F Ceramic | Ceramic Capacitor, X7R, 16V, 0.47 μ F | 0805 | Any | 1 |
| C10 | 6.3ZA330 | Al. Electrolytic Capacitor, 6.3V, 330 μ F | 8 x 11.5 | Rubycon | 1 |
| C11-14, 19, 24 | 6.3ZA1000 | Al. Electrolytic Capacitor, 6.3V, 1000 μ F | 10 x 16 | Rubycon | 6 |
| C20 | 10pF Ceramic | Ceramic Capacitor, X7R, 50V | 0603 | Any | 1 |
| C22 | 22nF Ceramic | Ceramic Capacitor, X7R, 25V | 0603 | Any | 1 |
| C25, 26 | 6MV1000CA | Al. Electrolytic Capacitor, 6.3V, 1000 μ F | 8 x 11.5 | Sanyo | 2 |
| C27-29 | 0603YC104MAT2A | Ceramic Capacitor, X7R, 16V, 0.1 μ F | 0603 | AVX | 3 |
| C17, 21 | Spare | | 0805 | | |
| D1 | MA732CT-ND | Schottky Diode, 30V, 30mA | Mini 2P | Digikey | 1 |
| DA1-3 | MA121CT-ND | Diode Array, 80V, 100mA | Mini 6P | Digikey | 3 |
| F1 | 4182100000 | Fuse, 75V, 10A | 2.5 x 6.0 | Wickmann | 1 |
| J1 | 39-29-9203 | 20-pin Mini-Fit, Jr. TM Header Connector | | Molex | 1 |
| JP1-4 | 68000-236 | Jumper Header | 0.1in. spacing | Berg | 10/36 |
| | 71363-102 | Jumper Shunt | 0.1in. spacing | Berg | 2 |
| L1 | 1.2 μ H Inductor | 6 Turns of 16AWG on T44-52 Core | 8 x 15 | Any | 1 |
| L2 | 2.5 μ H Inductor | 8 Turns of 16AWG on T50-52B Core | 10 x 17 | Any | 1 |
| LP1-7 | L63111CT-ND | Miniature LED, Through-Board Indicator | | Digikey | 7 |
| Q1,2 | HUF76129D3S | UltraFET MOSFET, 30V, 16m Ω | TO-252AA | Fairchild | 2 |
| Q3 | FZT649 | NPN Bipolar, 25V, 3A | SOT-223 | Zetex | 1 |
| Q4,5 | 2SD1802 | NPN Bipolar, 50V, 3A | TO-252AA | Sanyo | 2 |
| Q6 | HUF76145S3S | UltraFET MOSFET, 30V, 5.5m Ω | TO-263 | Fairchild | 1 |
| Q7 | ITF86172SK8T | TrenchFET MOSFET, 30V, 23m Ω | SO-8 | Siliconix | 1 |
| Q8 | BSS84ZXCT-ND | Logic P-MOSFET, 50V, 10 Ω | SOT-23 | Digikey | 1 |
| Q9, 10 | 2N7002 | Logic N-MOSFET, 25V, 5 Ω | SOT-23 | Any | 2 |
| QA1 | ZDM4206NCT-ND | Small-Signal Dual MOSFET, 60V, 1 Ω | SM-8 | Digikey | 1 |
| R1 | 12k Ω | Resistor, 5%, 0.1W | 0603 | Any | 1 |
| R2 | 12.7k Ω | Resistor, 1%, 0.1W | 0603 | Any | 1 |
| R3 | 5.90k Ω | Resistor, 1%, 0.1W | 0603 | Any | 1 |
| R5 | 0 Ω | Shorting Resistor | 0603 | Any | 1 |
| R6 | 9.09k Ω | Resistor, 1%, 0.1W | 0603 | Any | 1 |
| R7 | 7.15k Ω | Resistor, 1%, 0.1W | 0603 | Any | 1 |
| R8 | 1.50k Ω | Resistor, 1%, 0.1W | 0603 | Any | 1 |
| R10 | 45.3k Ω | Resistor, 1%, 0.1W | 0603 | Any | 1 |
| R11 | 7.50k Ω | Resistor, 1%, 0.1W | 0603 | Any | 1 |
| R12 | 8.45k Ω | Resistor, 1%, 0.1W | 0603 | Any | 1 |
| R13 | 698 Ω | Resistor, 1%, 0.1W | 0603 | Any | 1 |
| R14 | 30 Ω | Resistor, 5%, 0.1W | 0603 | Any | 1 |
| R15 | 510 Ω | Resistor, 5%, 0.1W | 0603 | Any | 1 |
| R16 | 680 Ω | Resistor, 5%, 0.1W | 0603 | Any | 1 |
| R17 | 10k Ω | Resistor, 5%, 0.1W | 0603 | Any | 1 |
| R4,9 | Spare | | 0603 | | |
| RN1 | Y9102CT-ND | 4-Resistor Network, 1.0k Ω , 5%, 0.1W | 3.2 x 1.6 | Digikey | 1 |

Bill of Materials for ISL6432EVAL1

| REFERENCE | PART NUMBER | DESCRIPTION | PACKAGE | MANUF. OR VENDOR | QTY |
|--|-------------|--|--------------|------------------|-----|
| RN2 | Y9681CT-ND | 4-Resistor Network, 680Ω, 5%, 0.1W | 3.2 x 1.6 | Digikey | 1 |
| RN3,4 | Y8103CT-ND | 2-Resistor Network, 10kΩ, 5%, 0.1W | 1.6 x 1.6 | Digikey | 2 |
| RN5 | Y8681CT-ND | 2-Resistor Network, 680Ω, 5%, 0.1W | 1.6 x 1.6 | Digikey | 1 |
| SW1 | GT12MSCKE | Miniature Switch, Single Pole, Single Throw | | C&K | 1 |
| SW2 | GT23MSCKE | Miniature Switch, Double Pole, Double Throw, On-Off-On | | C&K | 1 |
| SW3 | GH1008-ND | Miniature Rocker Switch, 8-Pole, Single Throw | | Digikey | 1 |
| TP1-4 | 1314353-00 | Test Point, Scope Probe | | Tektronics | 4 |
| TP5-10 | SPCJ-123-01 | Test Point | | Jolo | 6 |
| U1 | ISL6432CB | Synchronous Switcher and Triple Linear Controller | SOIC-16 | Intersil | 1 |
| U2 | NC7S00 | 2-Input NAND Gate | 5-Pin SOT-23 | Fairchild | 1 |
| U3, 4 | NC7S08 | 2-Input AND Gate | 5-Pin SOT-23 | Fairchild | 2 |
| U5, 6 | NC7S04 | CMOS Inverter | 5-Pin SOT-23 | Fairchild | 2 |
| +3.3VDUAL, +3.3VIN, +5VDUAL, +VOUT1, +VOUT2, +VOUT3, +VOUT4, GND | 1514-2 | Terminal Post | | Keystone | 14 |

NOTE:

1. Mount SW1 such that the side with the part marking faces the white dot in the solder mask.

ISL6432EVAL1 Layout

TOP SILK SCREEN

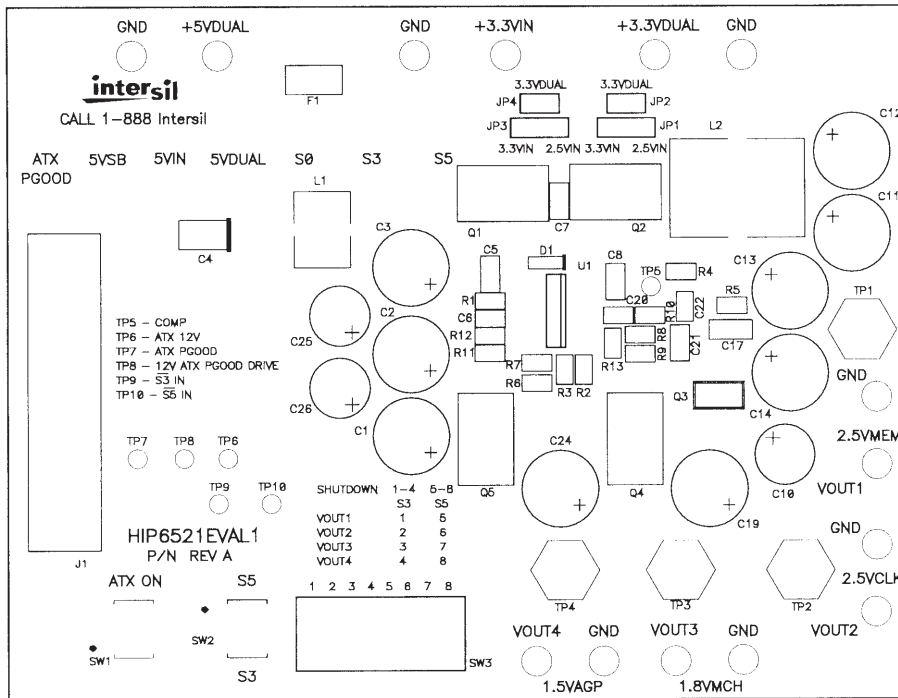

ISL6432EVAL1 Layout (Continued)

TOP LAYER

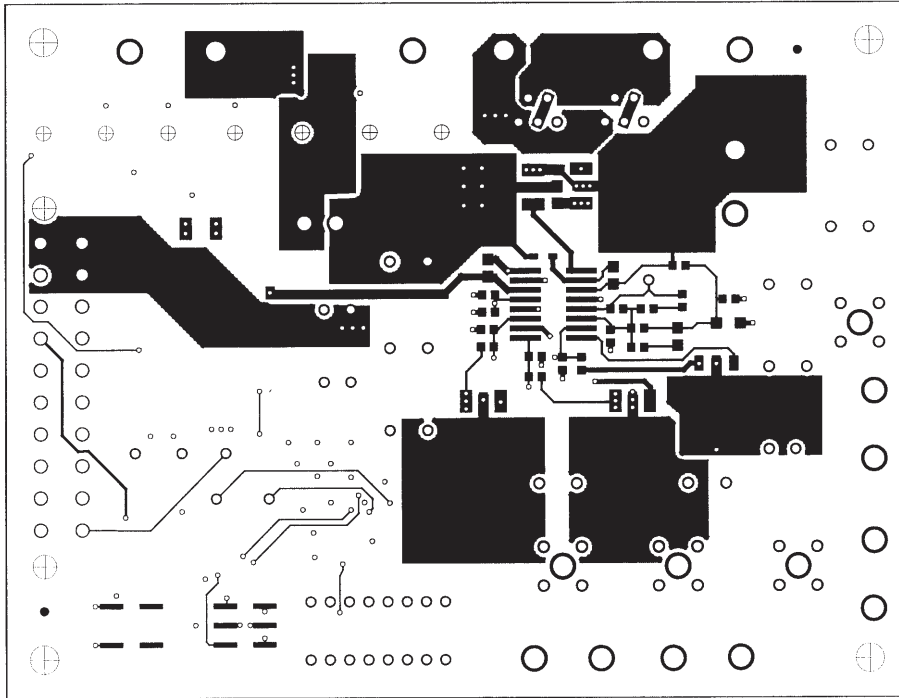

GROUND LAYER

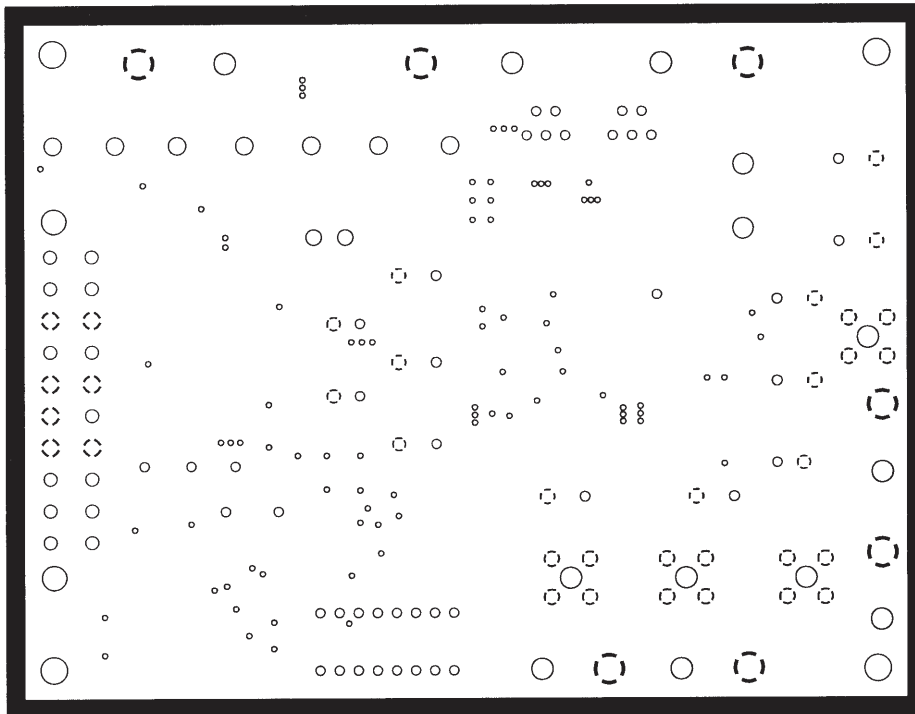

ISL6432EVAL1 Layout (Continued)

POWER LAYER

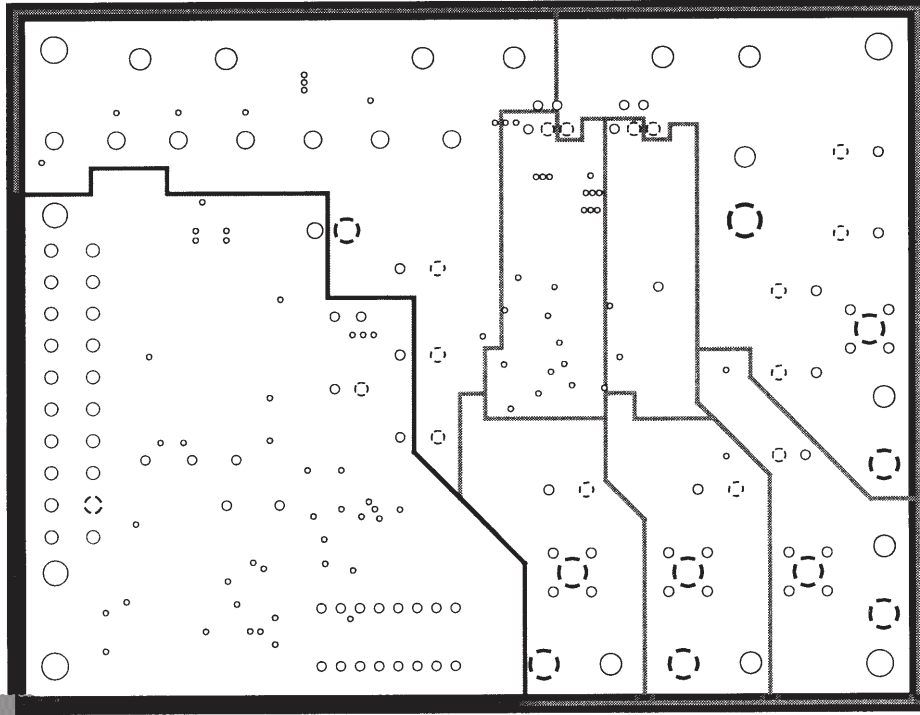

BOTTOM LAYER

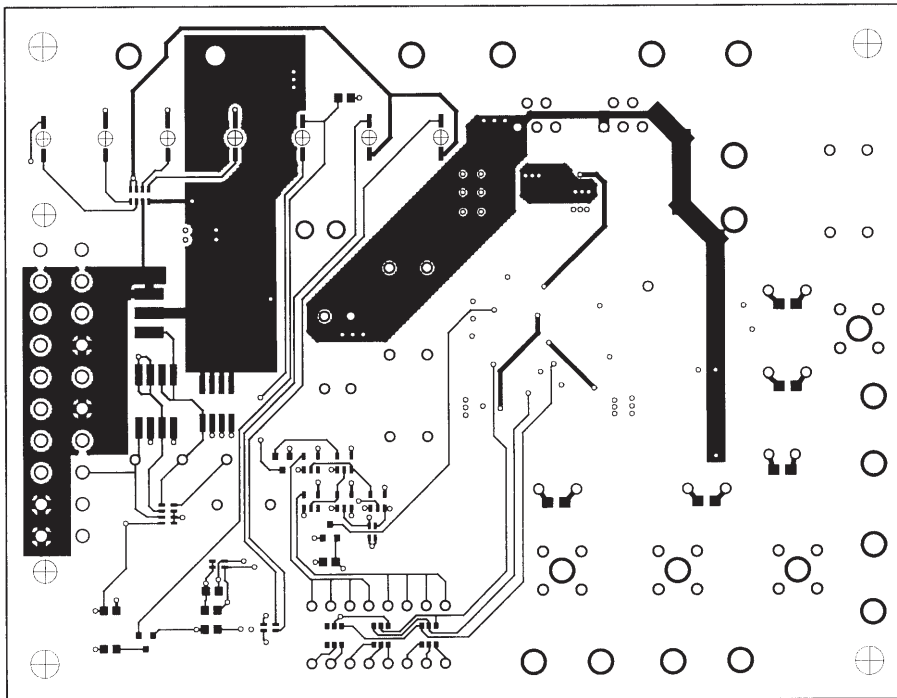

ISL6432EVAL1 Layout (Continued)

BOTTOM SILK SCREEN

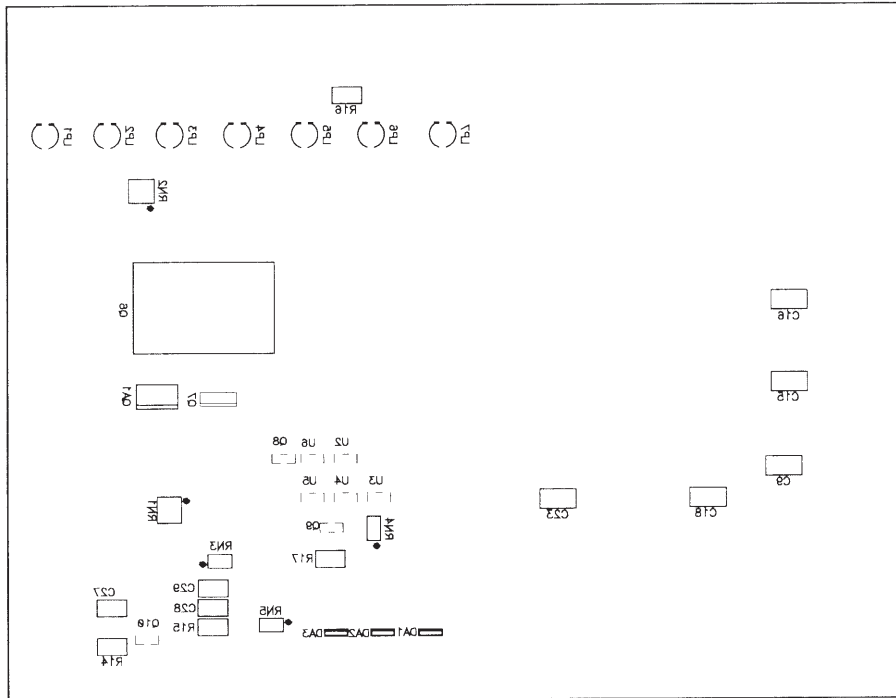

All Intersil products are manufactured, assembled and tested utilizing ISO9000 quality systems.
Intersil Corporation's quality certifications can be viewed at www.intersil.com/design/quality

Intersil products are sold by description only. Intersil Corporation reserves the right to make changes in circuit design and/or specifications at any time without notice. Accordingly, the reader is cautioned to verify that data sheets are current before placing orders. Information furnished by Intersil is believed to be accurate and reliable. However, no responsibility is assumed by Intersil or its subsidiaries for its use; nor for any infringements of patents or other rights of third parties which may result from its use. No license is granted by implication or otherwise under any patent or patent rights of Intersil or its subsidiaries.

For information regarding Intersil Corporation and its products, see www.intersil.com

Sales Office Headquarters

NORTH AMERICA
Intersil Corporation
7585 Irvine Center Drive
Suite 100
Irvine, CA 92618
TEL: (949) 341-7000
FAX: (949) 341-7123

Intersil Corporation
2401 Palm Bay Rd.
Palm Bay, FL 32905
TEL: (321) 724-7000
FAX: (321) 724-7946

EUROPE
Intersil Europe Sarl
Ave. C - F Ramuz 43
CH-1009 Pully
Switzerland
TEL: +41 21 7293637
FAX: +41 21 7293684

ASIA
Intersil Corporation
Unit 1804 18/F Guangdong Water Building
83 Austin Road
TST, Kowloon Hong Kong
TEL: +852 2723 6339
FAX: +852 2730 1433